

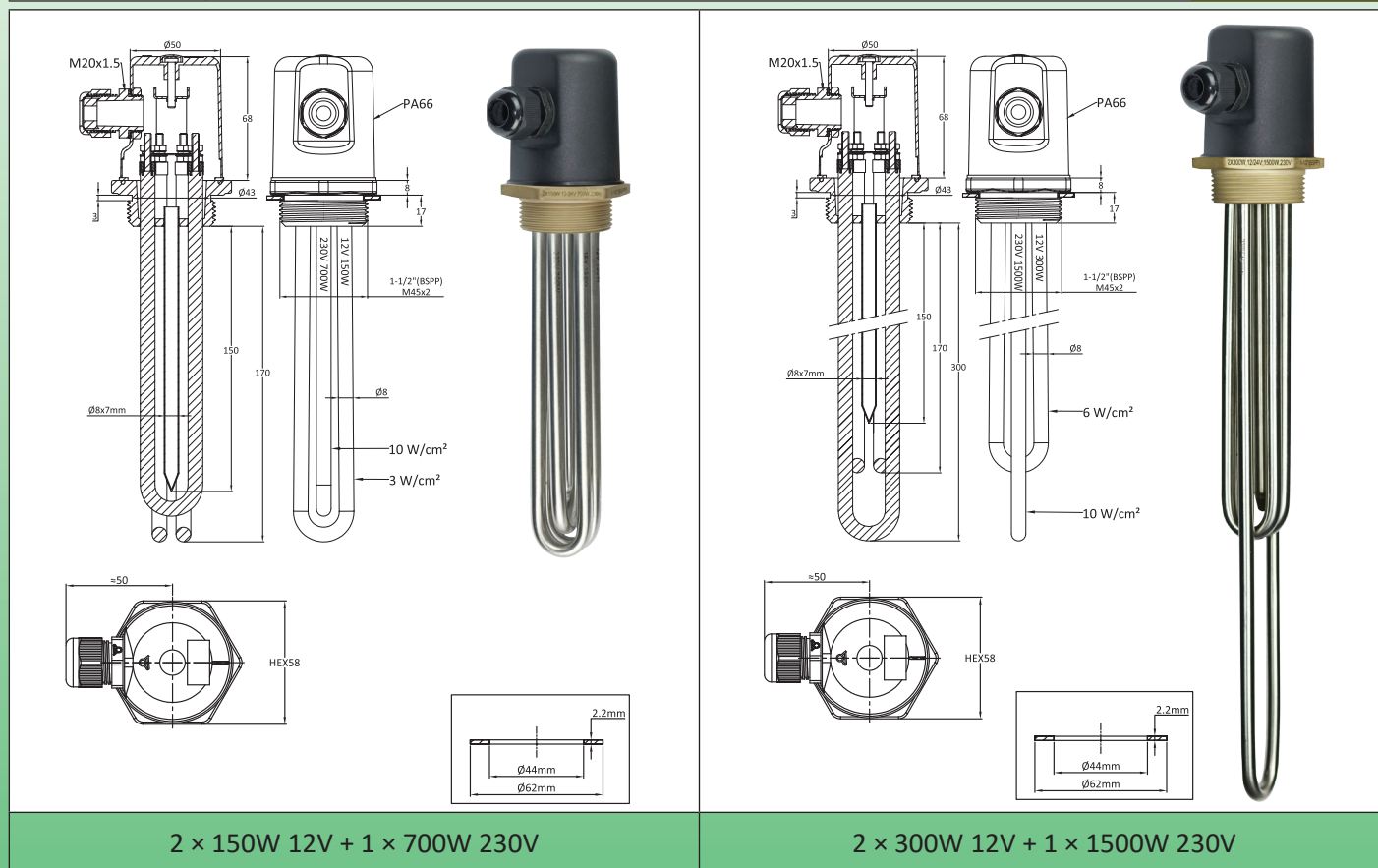

Renewable energy immersion heaters

Renewable energy 1½" and M45x2 immersion heaters, 12 and 24V power supply with 230V auxiliary heating element, with connection box

Main Voltage	Low voltage Power	Auxiliary voltage	Auxiliary Power	Enclosure	Threads	Type
12V, 24V	2 × 150W or 2 × 300W	230V	700W or 1500W	With	1½" or M45x2	9SFN202 and 9SFN502



Main application: direct use of low voltage electricity produced by wind turbines or photovoltaic solar panels, for heating liquids, domestic hot water circuits, hot water tanks. These immersion heaters make it possible to use the surplus energy produced, and not used by domestic lighting needs or small electrical appliances. They can also be used in addition to domestic hot water tanks, limiting the need for electricity from the distribution network.

Heater tube material: dia. 8mm heating elements in AISI 304 (AISI 316; AISI 321; Incolloy 800 or Incolloy 840 on request).

Fitting material: Brass, brazed on tubes. Supplied with one fiber gasket but without nut. See accessories below.

Thread: 1½" BSPP (ISO 228) and metric thread M45x2

Enclosure: dia. 58mm × 75mm, black PA66 fiber glass reinforced, with gasket. Opening by center M4 screw without access to end user. (When the screw cap is pushed in, it is impossible to remove the cover)

Ingress protection class: IP66.

Cable gland: M20, PA66.

Thermowell: Includes one stainless steel thermowell 7mm ID.

Heating elements connections: Terminals with M4 stainless steel screw, nut and stainless steel washer. Supplied with brass straps for switching the two low voltage heaters from 12V to 24V. (Changing their connection from parallel to serial).

Low voltage heating elements are identified by a red sleeve. 230V heating elements are identified by a black sleeve.

Not heating immersed zone: 50mm.

Surface load: see drawings

Voltage: 12 or 24V DC or AC and single phase 230V for models with auxiliary power heater

Attention: Switching by a thermostatic device the heating elements in low voltage must be made by device designed for low voltage use, and withstanding the important intensity of these circuits. Similarly, the section of the power cables must be adapted.



Renewable energy immersion heaters

Intensity flowing in low voltage heating circuits

Voltage	Power		
	150W	300W	600W
12V	12.5A	25A	50A
24V	6.2A	12.5A	25A

Electric Wiring

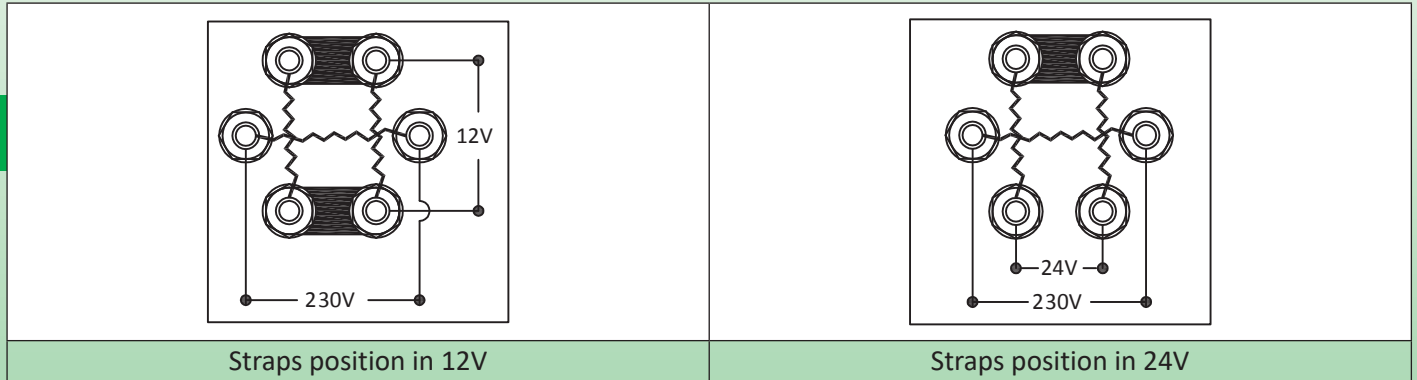

Main references

Fitting thread	1½" BSPP		M45 × 2	
	2 × 150W 12V + 1 × 700W 230V	2 × 300W 12V + 1 × 1500W 230V	2 × 150W 12V + 1 × 700W 230V	2 × 300W 12V + 1 × 1500W 230V
Length (mm)	170	300	170	300
Surface load of 12/24V heating elements	3W/cm ²	6W/cm ²	3W/cm ²	6W/cm ²
Surface load of the 230V heating element	10W/cm ²	10W/cm ²	10W/cm ²	10W/cm ²
Reference in AISI 304	9SFN202152307217	9SFN202302615230	9SFN502152307217	9SFN502302615217
Reference in Incolloy 800	9SFN202152307K17	9SFN202302615K30	9SFN202152307K30	9SFN502302615K30

References of Brass Nuts

1½"	66NLC11280H52
M45 × 2	66NLM45280H52